

## PRECISION ANGLE DRESSING DEVICE

SAV 434.03

For angle dressing of grinding wheels

**Application:**

Using this tool grinding wheels can be simply dressed and cut back in any angle or shape. For dressing of straight, angled and side faces. For grinding end faces, slots and precise angled surfaces.

**Features:**

Can be tilted over 90° in both directions from the vertical position. Adjustable using graduated scale.

Adjustable application head for the diamond. Diameter 6 mm, stroke 10 mm SAV 439.60. included in the delivery.

**Accessories:**

Dressing diamond SAV 401.01 - 06  
Supplied at a surcharge.

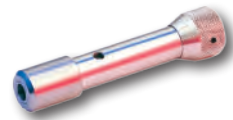
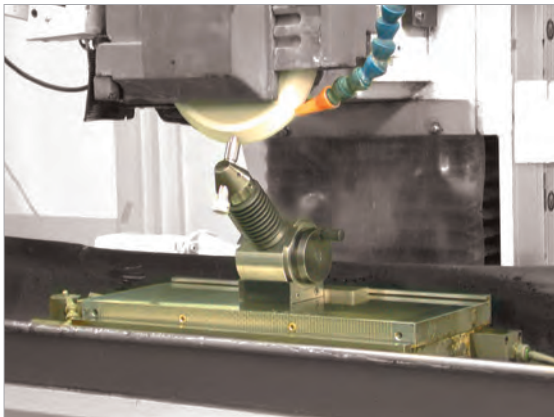

Adjustable application head for diamond SAV 439.60 (included in the delivery)

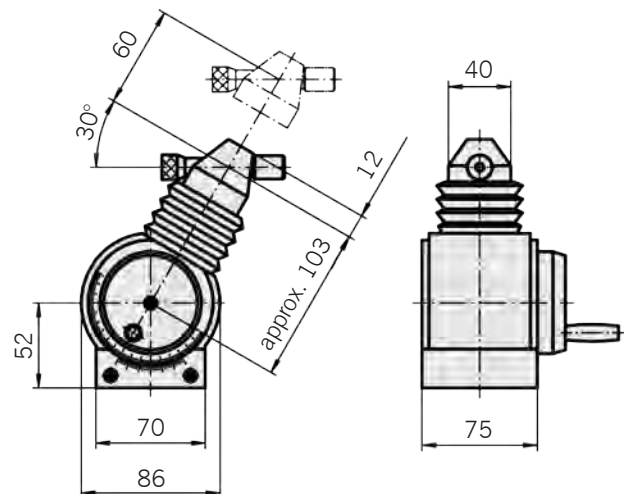

Base area approx.	in mm	70 x 75
max. stroke	in mm	60
Bore hole for diamond	in mm	6
Weight	in kg	4,1
Swivel range	in °	± 90

**Ordering example:**

Precision Angle Dressing Device SAV 434.03  
Designation SAV - No.